

gtx速度

	Type	Max Performance ¹	Max Transceivers	Peak Bandwidth ²
Versal ACAP	GTU/GTM	32.75/58.0	44/52	6,032Gb/s
Versal Premium Series	GTU/GTM	32.75/112.0	28/70	9,040Gb/s
Virtex® UltraScale+	GTU/GTM	32.75/58.0	128/48 ³	8,384Gb/s
Kintex® UltraScale+	GTH/GTY	16.3/32.75	44/32	3,268Gb/s
Virtex UltraScale	GTH/GTY	16.3/30.5	60/60	5,616Gb/s
Kintex UltraScale	GTH	16.3	64	2,086Gb/s
Virtex-7	GTX/GTH/GTZ	12.5/13.1/28.05	56/96/16 ³	2,784Gb/s
Kintex-7	GTX	12.5	32	800Gb/s
Artix®-7	GTP	6.6	16	211Gb/s
Zynq® UltraScale+	GTR/GTH/GTY	6.0/16.3/32.75	4/44/28	3,268Gb/s
Zynq-7000	GTX	12.5	16	400Gb/s
Spartan-6	GTP	3.2	8	51Gb/s

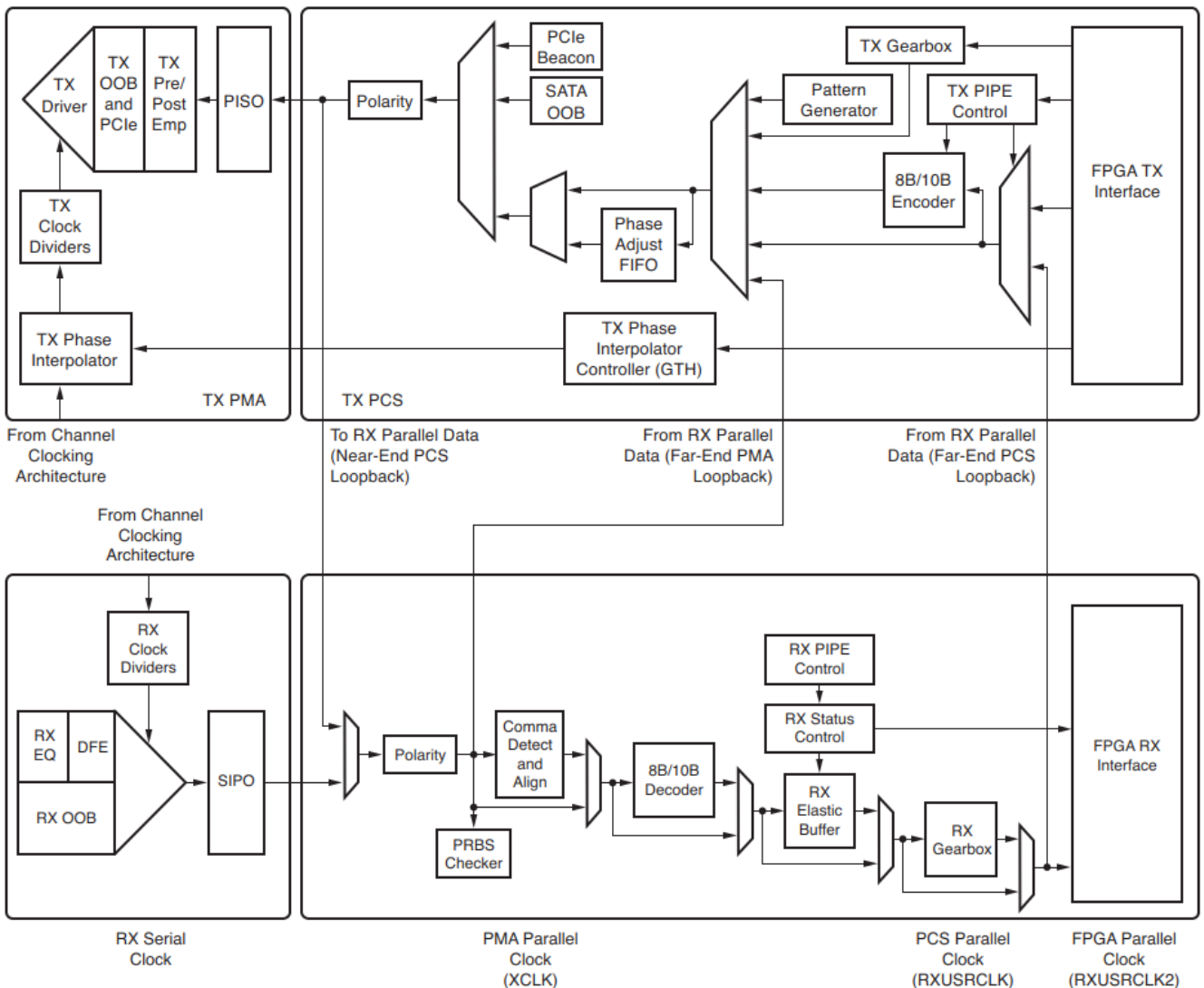

UG476_ct_03_112311

Figure 1-3: GTXE2_CHANNEL Primitive Topology

