

verilog

vcs仿真参考 [vcs使用](#)

1. 异步复位

异步复位，同步释放，复位释放时需和clk满足时序关系。

```
always@(posedge clk or negedge rst_n) begin
  if (!rst_n) begin
    end else begin
    end
end
```

2. 同步复位

同步复位时rst_n拉低，时钟需要一直有。

```
always@(posedge clk) begin
  if (!rst_n) begin
    end else begin
    end
end
```

3. 无毛刺切换电路

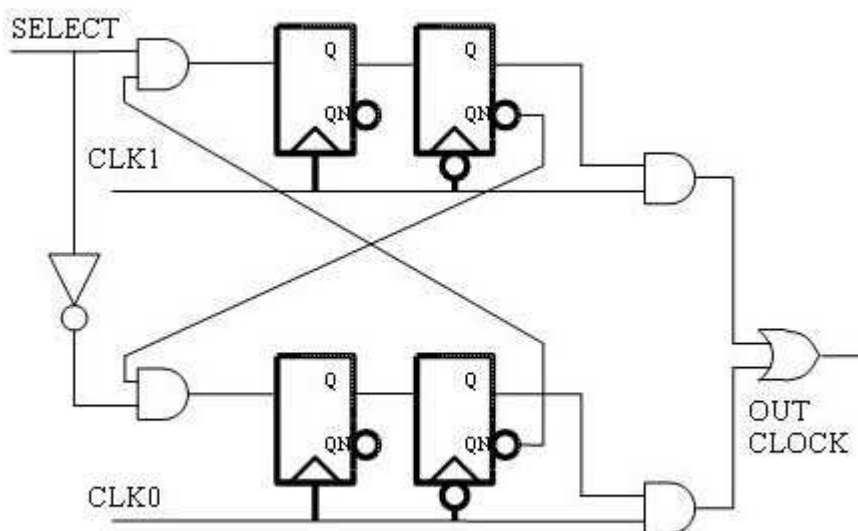

4. 操作符优先级

Table 12—Precedence rules for operators

+ - ! ~ (unary)	Highest precedence
**	
* / %	
+ - (binary)	
<< >> <<< >>>	
< <= > >=	
== != === !==	
& ~&	
^ ~^ ~^	
~	
&&	
?: (conditional operator)	

5. 驱动强度

Drive strength
four driving strengths:

supply strong pull weak

```
assign (strong1, pull0) mynet = enable ;
```

The charge strength specification shall be used only with trireg nets.
three charge storage strengths:

large medium small

```
# Strength name Strength level
# supply0 7
# strong0 6
# pull0 5
# large0 4
# weak0 3
# medium0 2
# small0 1
```

```
# highz0 0
# highz1 0
# small1 1
# medium1 2
# weak1 3
# large1 4
# pull1 5
# strong1 6
# supply1 7
```

6. define使用

```
#`` 拼接
```

```
`define NAME yb
`define INST `NAME``_inst 等价于yb_inst
```

```
# args方式
# 比如有如下define定义
`define append(f) f``_master
```

```
# 当使用时
`append(clock) 等价于 clock_master
```

```
`define H(x) "Hello, x"
```

```
$display(`H(world));
```

```
#打印内容
```

```
Hello, world
```

7. fwrite

```
module file_test(
    );
    reg [3:0]data[0:15];
    reg [3:0]data2[0:15];
    integer handle1;
    integer i=0;
    initial
    begin
        $readmemb("num.txt",data); //默认文件在工程所在路径目录

        handle1 = $fopen("num2.txt","w");
        repeat(16)
        begin
            $fwrite(handle1,"%d\n",data[15-i]);
        end
    end
endmodule
```

```
        i = i+1;
    end
    $fclose(handle1);
end
endmodule
```

8. module parameter

如果port width是参数

```
module a #(parameter WIDTH=8) (
    input [WIDTH-1:0] datai,
    output [WIDTH-1:0] datao
);
assign datao = datai;
endmodule
```

9. generate

```
wire [7:0] d;
wire [7:0] q;
wire [7:0] q2;

a u_a[7:0] (
    .clk (clk),
    .rst_n (rst_n),
    .d (d[7:0]),
    .q (q[7:0])
);

genvar i;
generate
for (i=0;i<8;8=i+1) begin: a2inst
a u_a2 (
    .clk (clk),
    .rst_n (rst_n),
    .d (d[i]),
    .q (q2[i])
);
end
endgenerate
```

10. 加延时

```
initial begin
```

```
    forever #5 clk = ~clk;
end

initial begin
    #5 rst_n = 1'b1;
end

assign #1 clk2 = clk1;

always @(posedge clk)
    data2 <= #1 data1;
```

11. 仿真force注意

force某一个net时，要意识到，其它这个force会前后传递的
不只是当前看到的PIN的值被force成期望值,而且从这个点向两个方向都会传递值，传递出去的值可能不是仿真预期的，最后造成仿真FAIL□

如果不想影响更多的点，可能是要想办法把线给断开，只有期望点才会被force□