

tessent occ

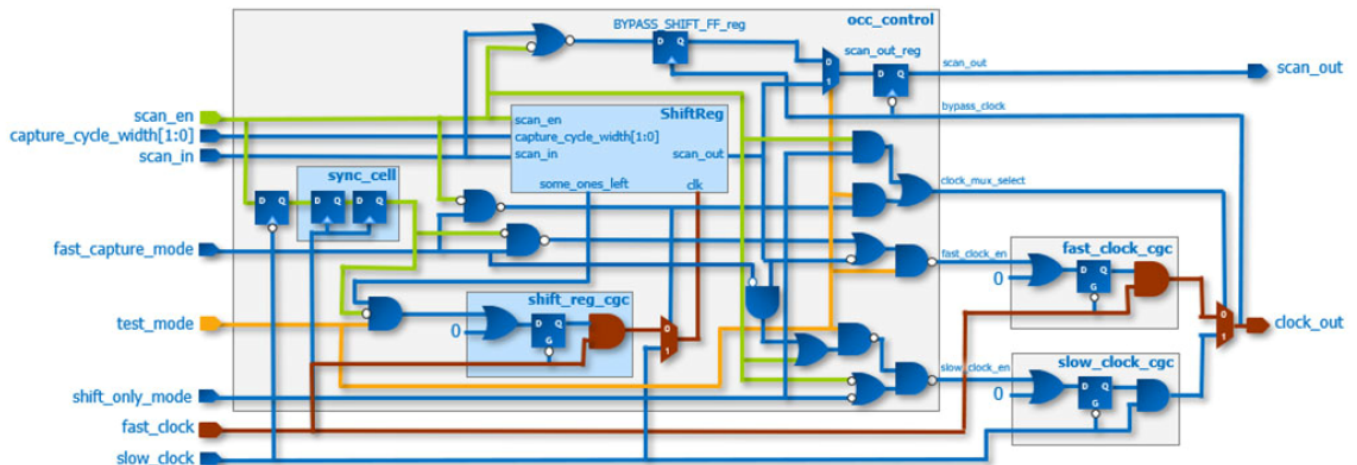

1. operation mode

1.1 function mode

functional mode ($\text{test_mode} = 0$) that enables the fast clock gater to supply a fast clock to the design.

1.2 shift mode

shift mode ($\text{scan_en} = 1$) that uses the `slow_clock` to load and unload the scan chains, including the condition bits in ShiftReg.

1.3 shift only mode

Shift-only mode **disables the OCC** ($\text{test_mode} = 0$) and **activates shift** ($\text{scan_en} = 1$). It enables the slow clock clock gater to use the slow clock path for shift, and it enables bypass shift.

这个信号默认需要连接到 DFT信号`ext_ltest_en`

1.4 slow capture mode

slow capture mode ($\text{fast_capture_mode} = 0$) that uses the `slow_clock` to capture data into the scan cells and to shift the condition bits in ShiftReg.

1.5 fast capture mode

fast capture mode ($\text{fast_capture_mode} = 1$) that uses the `fast_clock` to capture data into the scan

cells and to shift the condition bits in ShiftReg.

1.6 kill clock mode

kill clock mode (kill_clock_en = 1) that enables you to block propagation of fast_clock input to clock_out output. Asserting the kill_clock_en signal is effective in the two operating modes when the OCC is not active:

2. 结构伪代码

```
clock_mux21 tessent_persistent_cell_inject_tck_mux (
    .A0          ( slow_clock_buf_out
),
    .A1          ( ijtag_tck
),
    .S0          ( inject_tck
),
    .Y          ( slow_clock_tck_injected
)
);

cgand tessent_persistent_cell_cgc_fast_clock (
    .CK          ( fast_clock_buf_out
),
    .FE          ( fast_clock_en
),
    .TE          ( fast_clock_en
),
    .GCK         ( fast_clock_gated
)
);

cgand tessent_persistent_cell_cgc_slow_clock (
    .CK          ( slow_clock_tck_injected
),
    .FE          ( slow_clock_en
),
    .TE          ( slow_clock_en
),
    .GCK         ( slow_clock_gated
)
);

clock_mux21 tessent_persistent_cell_clock_out_mux (
    .A0          ( fast_clock_gated
),
```

```

        .A1          ( slow_clock_gated
    ),
        .S0          ( clock_mux_select
    ),
        .Y           ( clock_out
    )
    );

    assign kill_clock_en_gated = kill_clock_en & ~test_mode;
    assign fast_clock_en      = ((ShiftReg_SCAN_OUT & fast_capture_mode &
(SCAN_EN_inv_sync || active_upstream_parent_occ)) | (~test_mode)) &
(~kill_clock_en_gated);
    assign slow_clock_en      = (((ShiftReg_SCAN_OUT & (~fast_capture_mode)) |
scan_en) & test_mode) | inject_tck | (shift_only_mode & scan_en);
    assign clock_mux_select = ((scan_en | (~fast_capture_mode)) & test_mode)
| inject_tck | (shift_only_mode & scan_en);

```

3. Parent mode

Parent-mode operation is one of the operating modes of the standard OCC.

This operating mode bypasses the OCC clock gating logic and performs clock selection only. It requires a downstream child-mode OCC to perform the clock gating and chopping.

Parent-mode, 父OCC只做时钟function clk 与shift clk之间进行切换，不做OCC的pluse gateing(这部分由child-OCC来实现)

tile parent mode OCC + child OCC, 类似于OCC复制

非SSN场景

top parent mode OCC + n个tile内部child OCC, 无需单独shift clock连线到tile, tile内部也不用单独check shift timing

如果多个top parent mode OCC(频率不同) + tile child OCC, function模式下不同频率时钟为异步关系，切换到shift模式下，全为shift时钟, scan register单chain存在skew, 需要插入latch

SSN场景

shfit clock都是走tile内部(由SSH产生), intest时不考虑tile与tile之间的shift clock skew差异，这时用标准OCC是最好的。

4. Child OCC

SSN好像是不支持child OCC

Child OCC有两种实现：

- 普通OCC的child mode

- child-only的OCC

```
# 级联OCC会报R27问题，配置成Parent OCC mode + child OCC mode就不会报这个问题。
add_core_instances -inst [get_inst top_rtl2_tessent_occ_parent_*] \
                    -parameter {parent_mode on fast_capture_mode on}
set_static_dft_signal_values retargeting3_mode 1
//set_drc_handling R27 warning
set_core_instance_parameters -instances \
                             coreb_i1/coreb_rtl2_tessent_occ_clka_inst -parameter_values \
                             {active_upstream_parent_occ on}
set_core_instance_parameters -instances \
                             coreb_i1/coreb_rtl2_tessent_occ_clkb_inst -parameter_values \
                             {active_upstream_parent_occ on}
set_core_instance_parameters -instances \
                             coreb_i1/coreb_rtl2_tessent_occ_clkc_inst -parameter_values \
                             {active_upstream_parent_occ on}
```

5. sync OCC

5.1 使用场景

对于分频时钟和不分频时钟之间path当做同步处理的情况，需要使用同步OCC

在任何场景下，分频只能发生在第一级sync-occ，后级的sync occ只能是使用前级sync-occ的时钟输出。

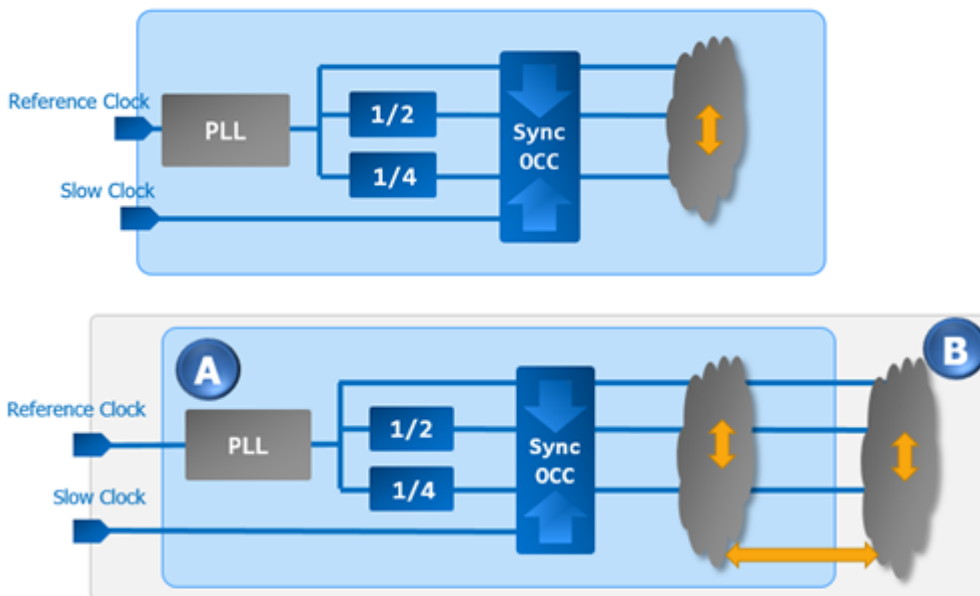

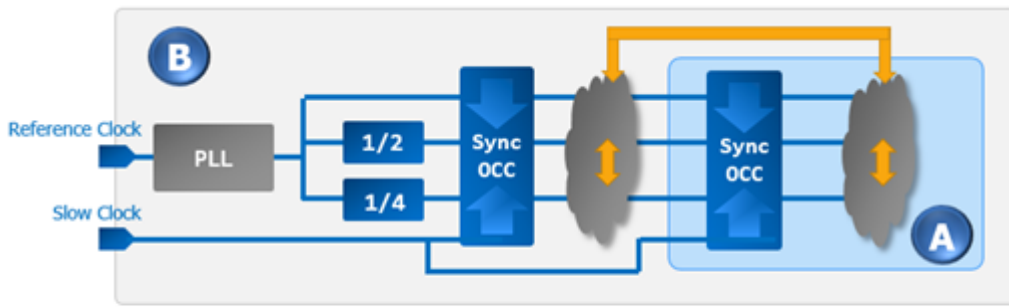

5.2 限制

sync occ后面不能接分频时钟。

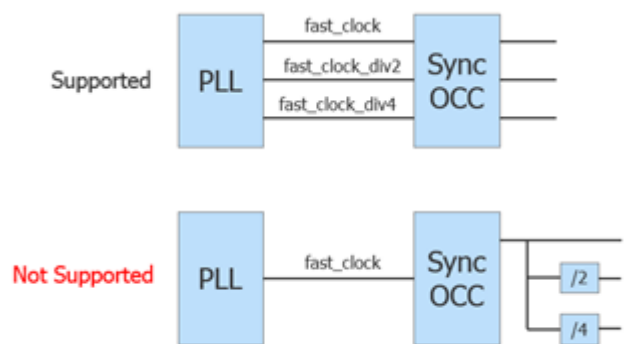

5.3 波形

有两种配置，我理解分别cover 低频到高频，高频到低频。

出capture pulse, 是使用低频时钟来出pulse的，高频在对应的位置点采用gating的方式，保证也只出2个pulse

