

1. datapath

1.1 pipeline

有三种pipeline, 这三种pipe从端口上来看时序是一样的, 最终效果都是用正沿打一拍

Receiver1xPipeline

前一级是用正沿打出来的, 这里先用负沿打一下是为了修hold 比如前级reg的clk tree比较短, 后级的clk tree比较长, 这样后级采样的时候hold容易出问题。

Receiver1xPipeline

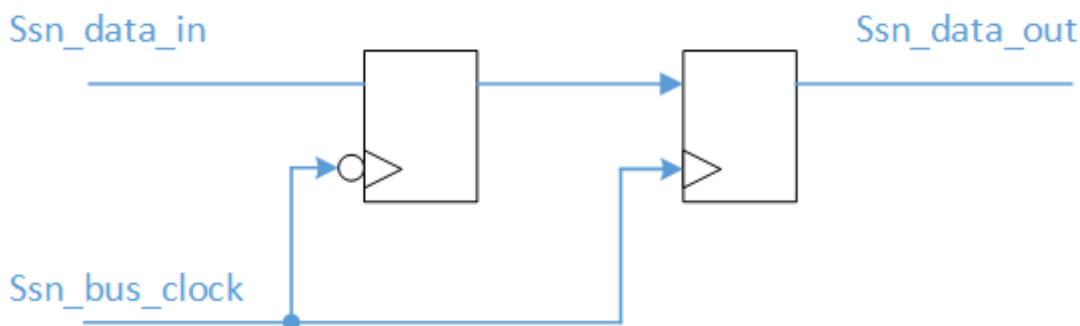

Pipeline

Pipeline

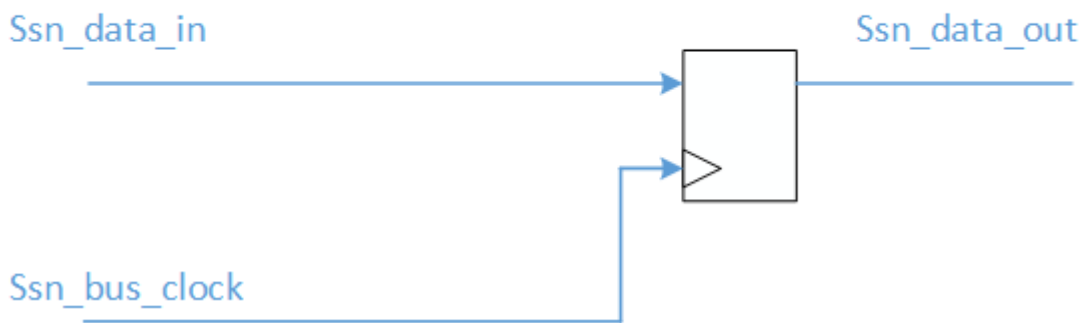

OutputPipeline

OutputPipeline

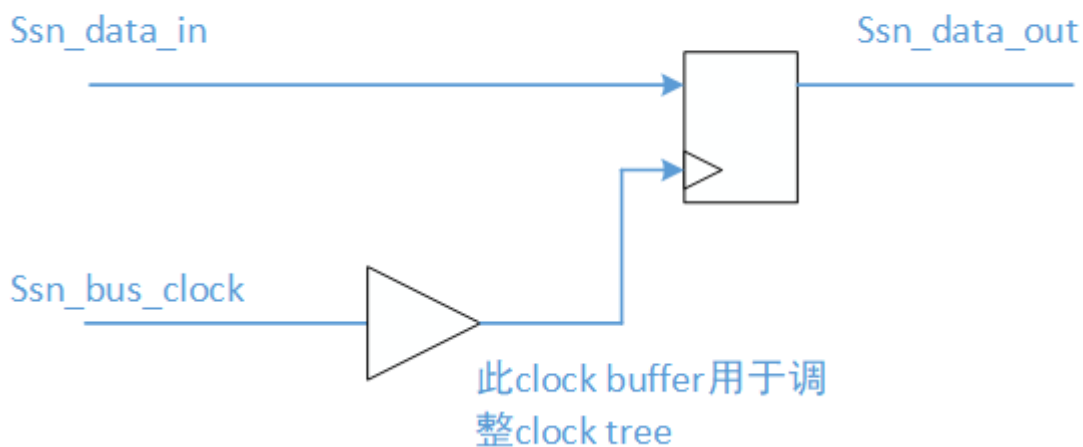

RxPipeline

ReceiverPipeline 定制

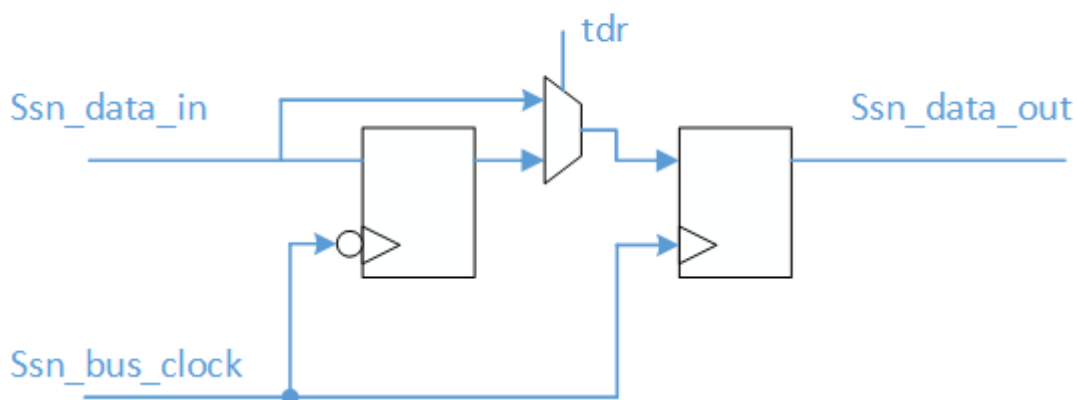

1.2 example 1

```
DataPath(1) {
  output_bus_width      : 2;
  Pipeline(2) {
  }
  ScanHost(1) {
  }
  Pipeline(1) {
  }
}
```

graph LR
 ssn_busin-->pipe1
 pipe1-->ssh
 ssh-->pipe2
 pipe2-->ssn_busout

1.3 example

```

DataPath(1) {
  output_bus_width      : 2;
  Pipeline(2) {
  }
  ScanHost(1) {
    OnChipCompareMode {
    }
  }
  Multiplexer(1) {
    Connections {
      secondary_bus_data_in : ssn_s0_bus_data_in[1:0];
    }
  }
  Pipeline(1) {
    ExtraOutputPath {
      Connections {
        bus_clock_out      : ssn_s0_bus_clock_out;
        bus_data_out       : ssn_s0_bus_data_out[1:0];
      }
    }
  }
}

```

graph LR
 ssn_busin-->pipe1
 pipe1-->mux1
 pipe1-->ssn_s0_bus_data_out
 ssn_s0_bus_data_out -.->ssn_s0
 ssn_s0-->mux1
 mux1-->ssh
 ssh-->pipe2
 pipe2-->ssn_busout

1.4 example

```

DataPath(1) {
  output_bus_width      : 2;
  ScanHost(1) {
    OnChipCompareMode {
    }
  }
  Multiplexer(2) {
    Connections {
      secondary_bus_data_in : ssn_s1_bus_data_in[1:0];
    }
  }
  Pipeline(2) {
    ExtraOutputPath {
      Connections {
        bus_clock_out      : ssn_s1_bus_clock_out;
        bus_data_out       : ssn_s1_bus_data_out[1:0];
      }
    }
  }
}

```

```

}
Multiplexer(1) {
  Connections {
    secondary_bus_data_in : ssn_s0_bus_data_in[1:0];
  }
}
Pipeline(1) {
  ExtraOutputPath {
    Connections {
      bus_clock_out      : ssn_s0_bus_clock_out;
      bus_data_out       : ssn_s0_bus_data_out[1:0];
    }
  }
}
}
}
}

```

```

graph LR
  ssn_busin-->pipe1
  pipe1-->mux1
  pipe1-->ssn_s0_bus_o
  ssn_s0_bus_o -.->ssn_s0
  ssn_s0-->mux1
  mux1-->pipe2
  pipe2-->mux2
  pipe2-->ssn_s1_bus_o
  ssn_s1_bus_o -.->ssn_s1
  ssn_s1-->mux2
  mux2-->ssh
  ssh-->ssn_busout

```

1.5 example

```

DataPath(1) {
  output_bus_width      : 2;
  Pipeline(8) {
  }
  ScanHost(1) {
    OnChipCompareMode {
    }
  }
  Multiplexer(1) {
    Connections {
      secondary_bus_data_in : ssn_s0_bus_data_in[1:0];
    }
    Pipeline(22) {
    }
  }
  Pipeline(1) {
    ExtraOutputPath {
      Connections {
        bus_clock_out      : ssn_s0_bus_clock_out;
        bus_data_out       : ssn_s0_bus_data_out[1:0];
      }
    }
  }
}
}
}

```

```

graph LR
  ssn_busin-->pipe1
  pipe1-->mux1
  pipe1-->ssn_s0_bus_o
  ssn_s0_bus_o -.->ssn_s0
  ssn_s0-->mux1

```

->pipe22 pipe22-->mux1 mux1-->ssh ssh-->pipe8 pipe8-->ssn_busout

1.6 example

```
DataPath(1) {
  output_bus_width      : 2;
  Pipeline(8) {
  }
  ScanHost(1) {
    OnChipCompareMode {
    }
  }
  Multiplexer(1) {
    Connections {
      secondary_bus_data_in : ssn_s0_bus_data_in[1:0];
    }
    Pipeline(22) {
    }
  }
  Pipeline(1) {
    ExtraOutputPath {
      Connections {
        bus_clock_out      : ssn_s0_bus_clock_out;
        bus_data_out       : ssn_s0_bus_data_out[1:0];
      }
      Pipeline(11) {
      }
    }
  }
}
```

graph LR
 ssn_busin-->pipe1
 pipe1-->mux1
 pipe1-->pipe11;
 pipe11-->ssn_s0_bus_o;
 ssn_s0_bus_o -.->ssn_s0
 ssn_s0-->pipe22
 pipe22-->mux1
 mux1-->ssh
 ssh-->pipe8
 pipe8-->ssn_busout