

atpg

1. Transition AC

DC的时候scan_en为0时，只有一拍时钟。scan_en下降沿与这一拍时钟的距离可以足够远，这个时钟也可以是高速或低速时钟。

AC的时候scan_en为0时，有两拍高速时钟（这里也可以配置为低速时钟。shift_as_capture mode）

AC有两种样本方式。LOC(比较常用)和LOS。

1.1 LOC

<https://www.cnblogs.com/6y4z/p/16588760.html>

Broadside (Launch-Off-Capture)

一般都是使用的这种结构，使用标准OCC即可生成期望时序。

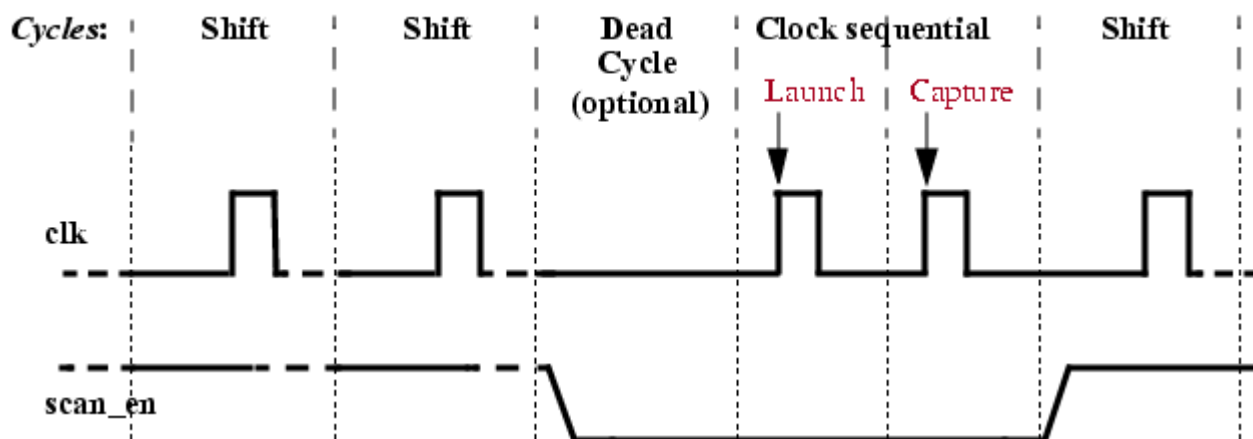

1.2 LOS

pseudo-Launch-Off-Shift (LOS)

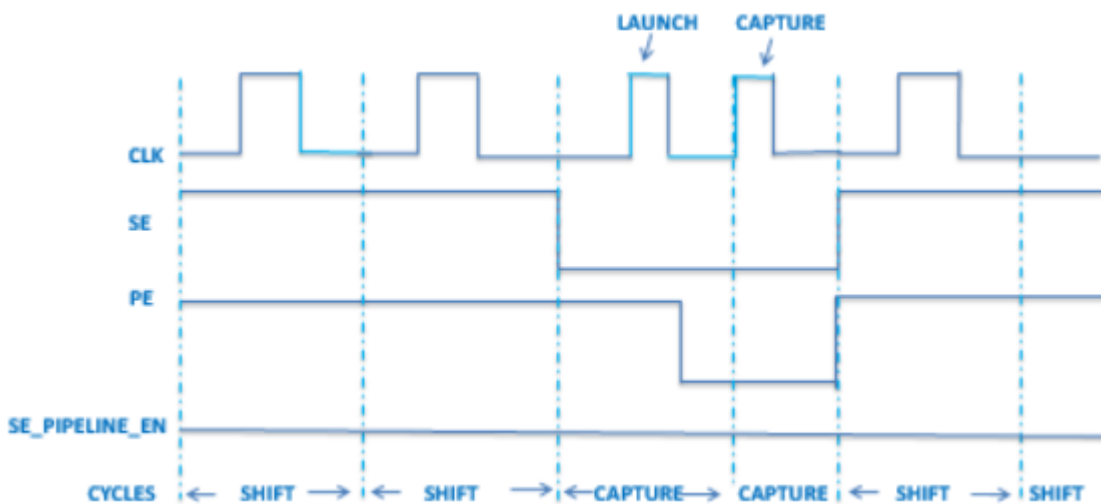
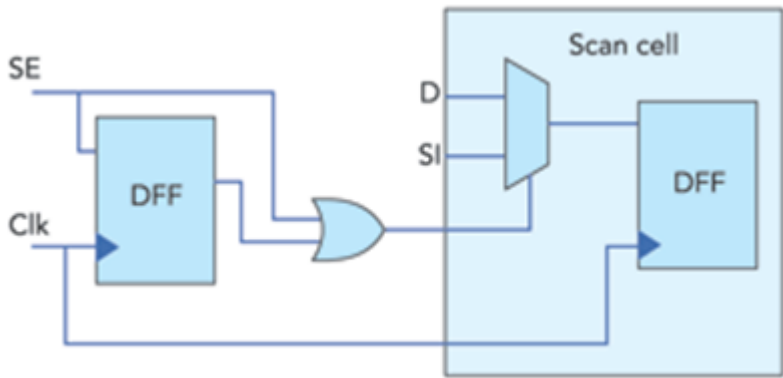
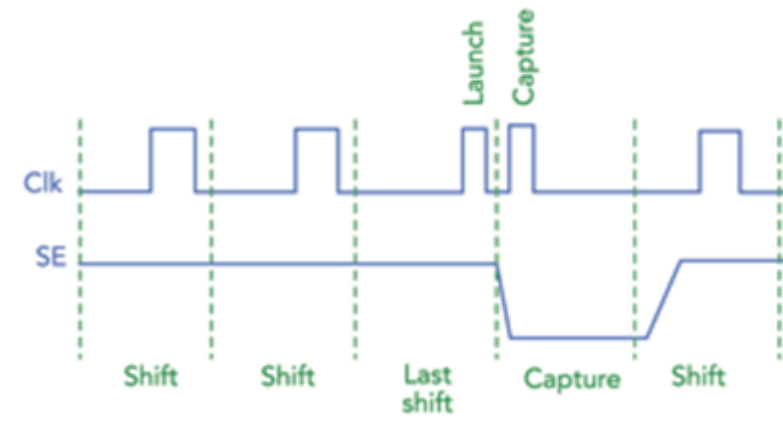

一直为1，开启se

pipeline enable

se_pipeline_en一直为1，开启se pipeline enable

这里的launch & capture都是高速时钟，可以理解为跟LOC一样，是OCC生成的。OCC在这看和LOC是一样的行为，只是launch值的区别。

2. pattern debug

Displayed data shows data during capture cycle clock frames of the reported pattern

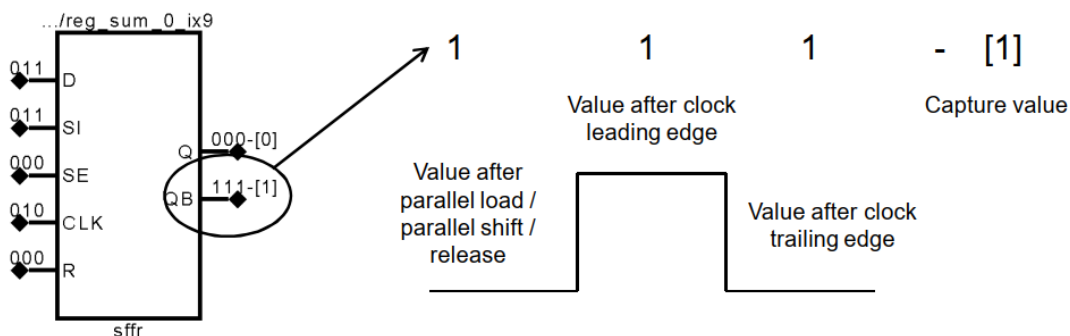

3. Pre-Existing Scan Chains

```
>add_scan_group grp1 chain_trace.testproc
>add_scan_chains -internal my_chain0 grp1 \
  corea_gate1_tessent_edt_cl_inst/edt_scan_in[0] \
  corea_gate1_tessent_edt_cl_inst/edt_scan_out[0]
>add_scan_chains -internal my_chain1 grp1 \
  corea_gate1_tessent_edt_cl_inst/edt_scan_in[1] \
  corea_gate1_tessent_edt_cl_inst/edt_scan_out[1]
```

这种会有一个问题，如果int_edt_mode和ext_edt_mode的chain有走部分公共路径，最后通过int/ext mode来区别chain如何分岔，这种不知道在drc trace scan chain时怎么处理。

gen atpg pattern

需要读取icl pdl, tcd, netlist文件，这样就可以跑出atpg pattern

```
// command: read_design gps_baseband -design_id gate -verbose
// sub-command: set_tool_options -reapply_settings_after_reelaboration On
// sub-command: set_read_design_tag gps_baseband
// sub-command: read_verilog
../tsdb_outdir/dft_inserted_designs/gps_baseband_gate.dft_inserted_design/gp
s_baseband.vg -no_duplicate_modules_warnings
// sub-command: set_read_design_tag ""
// sub-command: set_tool_options -reapply_settings_after_reelaboration Off
// sub-command: read_icl
../tsdb_outdir/dft_inserted_designs/gps_baseband_gate.dft_inserted_design/gp
s_baseband.icl -skip_child_blocks -no_notes
// sub-command: source
../tsdb_outdir/dft_inserted_designs/gps_baseband_gate.dft_inserted_design/gp
s_baseband.pdl
```

```
// sub-command: read_core_descriptions
../tsdb_outdir/dft_inserted_designs/gps_baseband_gate.dft_inserted_design/gp
s_baseband.tcd
```

4. set_atpg_limits

设置atpg process limits, 比如可以设置只出几条pattern[]这样可以快速得到一个简单的atpg pattern[]可以快速用于后续flow

```
set_atpg_limits -cpu_sec 500 -test_coverage 99.5 -pattern_count 2
report_environment
```

5. low power shift & capture

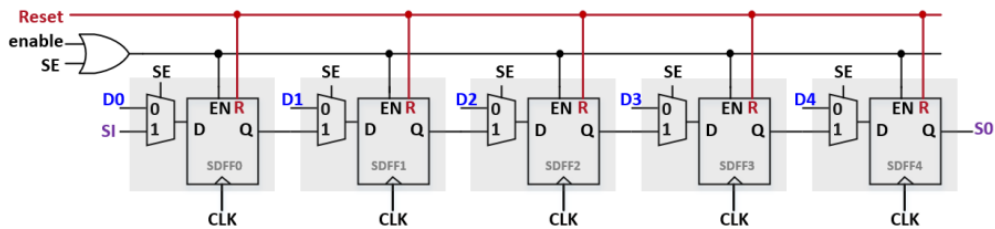

Fig. 1. Schematic design of regular scan chain with enable signal.

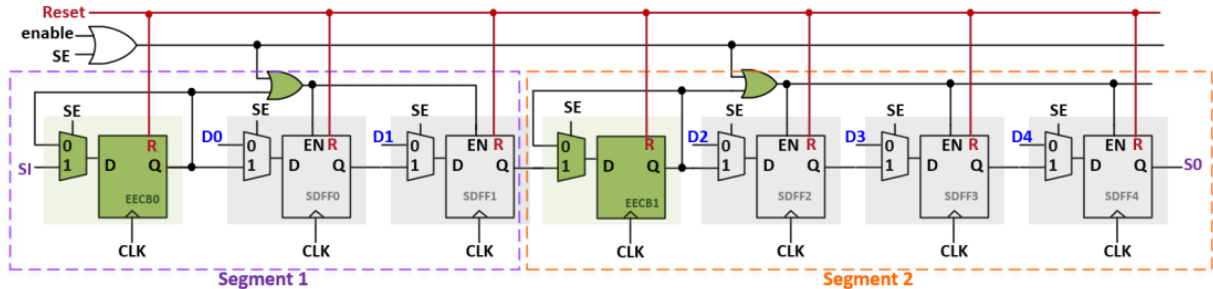

Fig. 2. Schematic design of segmented scan chain.

capture low power

用单独的几个scan cell(scan_en为0时保持cell值不变), 控制在capture阶段register的时钟enable 这样可以分段控制部分register在capture阶段数据不变, 实现low power效果

shift low power

主要是在shift阶段Q到function组合逻辑之间的通路加一个and/or门 让逻辑结合部分在shift阶段状态不变化,在capture阶段再变化。