

apb

apb读写传输分为地址阶段和数据阶段。

penable拉高，表示数据阶段开始。

1. apb 1.0

这个是最早的apb版本，是固定2个cycle完成读写操作。

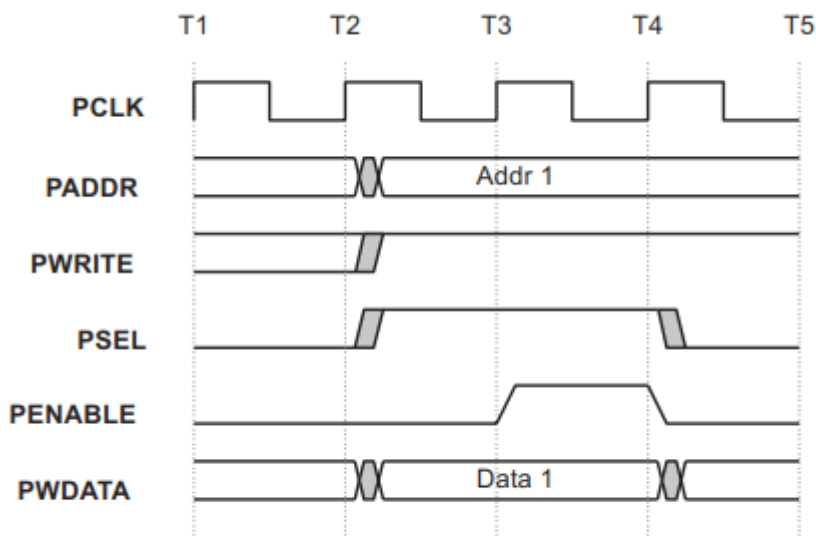

Figure 5-3 Write transfer

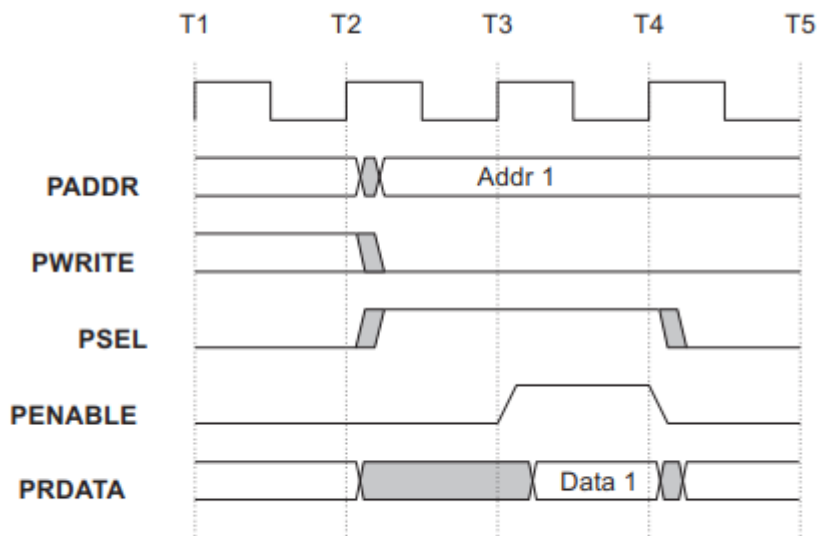

Figure 5-4 Read transfer

2. apb 2.0

这个是升级版本，数据阶段可以支持no ready wait

2.1 apb写不等

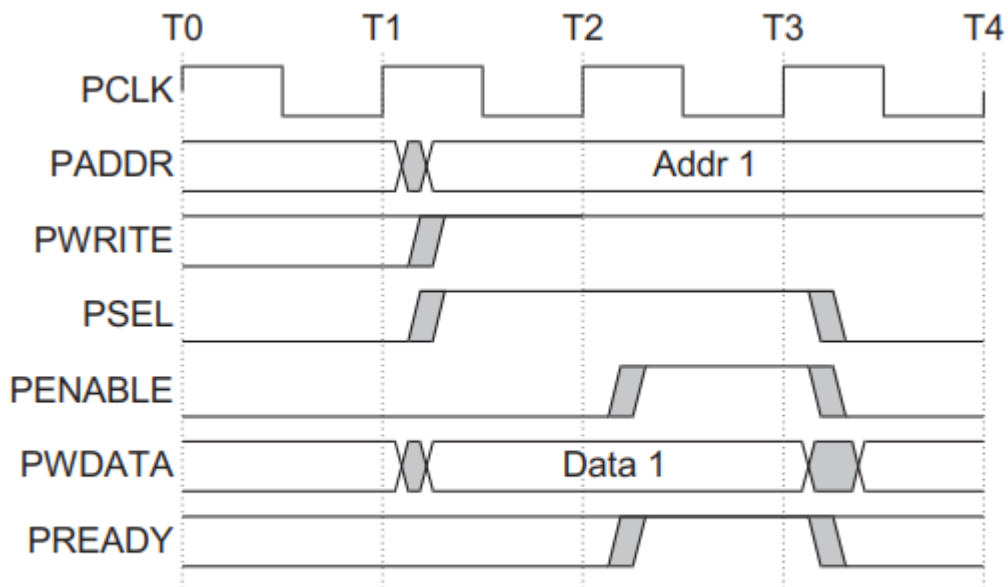

Figure 3-1 Write transfer with no wait states

2.2 apb写等

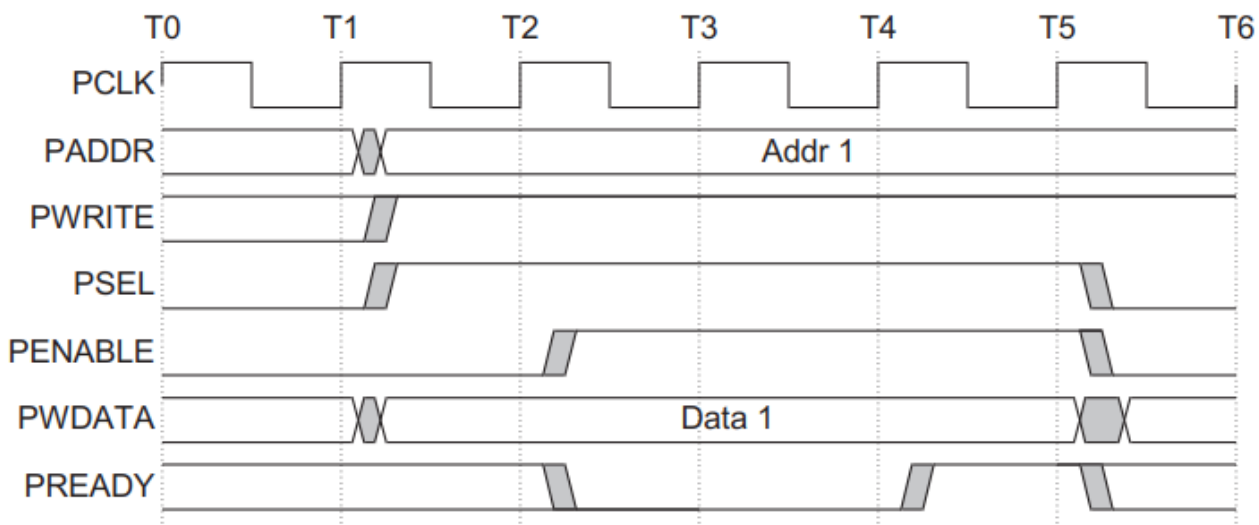

Figure 3-2 Write transfer with wait states

2.3 apb读不等

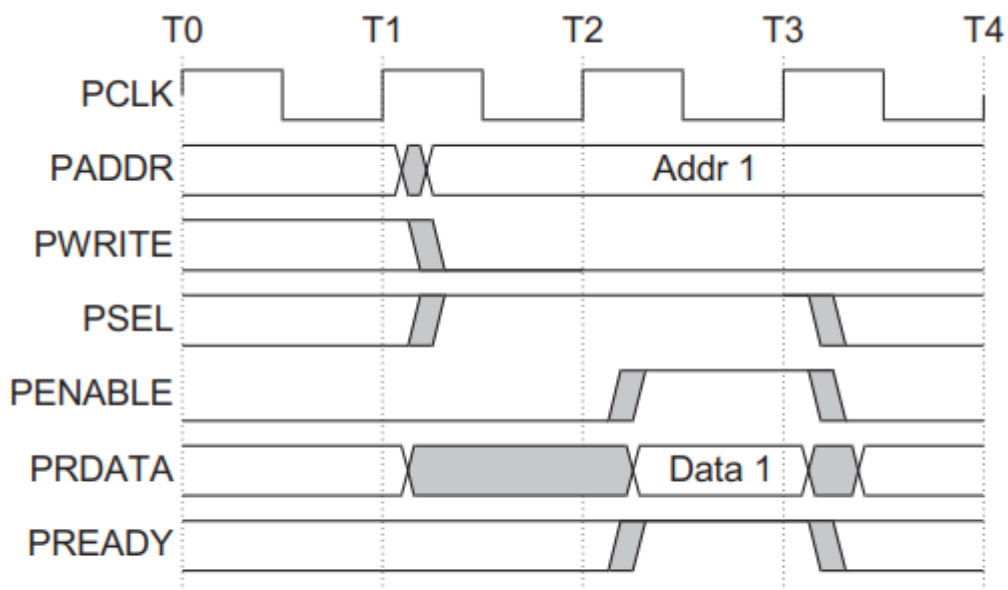

Figure 3-4 Read transfer with no wait states

2.4 apb读等

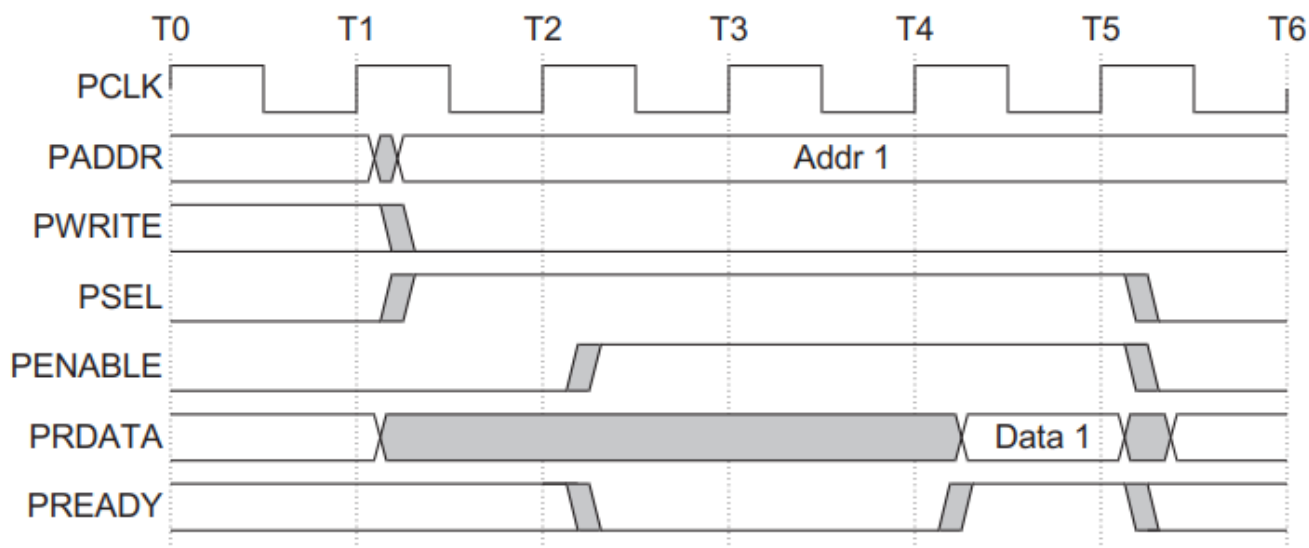

Figure 3-5 Read transfer with wait states

3. addr非对齐传输

Table 3-6 Active byte lanes for a 32-bit little-endian data bus

Transfer size	Address offset	DATA [31:24]	DATA [23:16]	DATA [15:8]	DATA [7:0]
Word	0	✓	✓	✓	✓
Halfword	0	-	-	✓	✓
Halfword	2	✓	✓	-	-
Byte	0	-	-	-	✓
Byte	1	-	-	✓	-
Byte	2	-	✓	-	-
Byte	3	✓	-	-	-