

apb

1. apb 1.0

这个是最早的apb版本，是固定2个cycle完成读写操作。

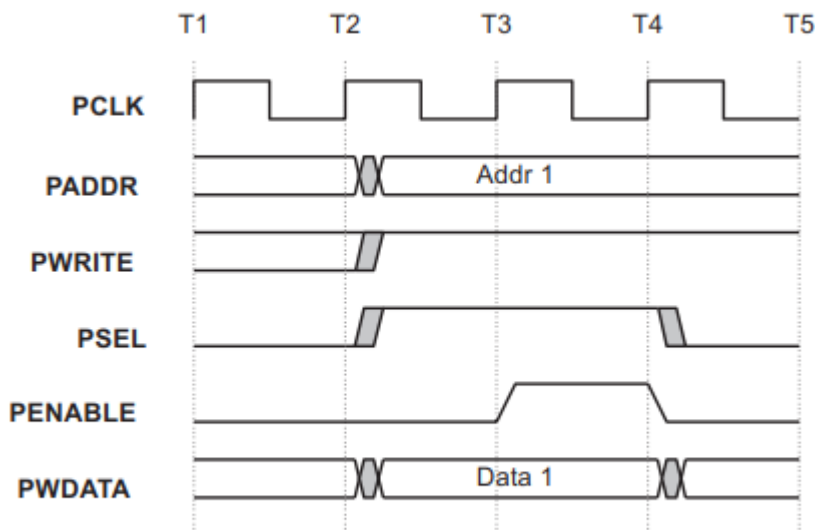

Figure 5-3 Write transfer

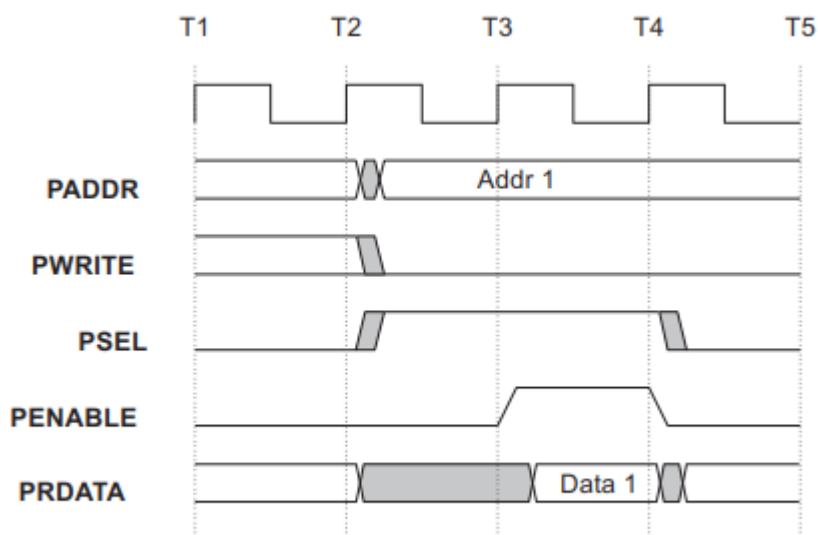

Figure 5-4 Read transfer

2. apb 2.0

这个是升级版本，数据阶段可以支持no ready wait

2.1 apb写不等

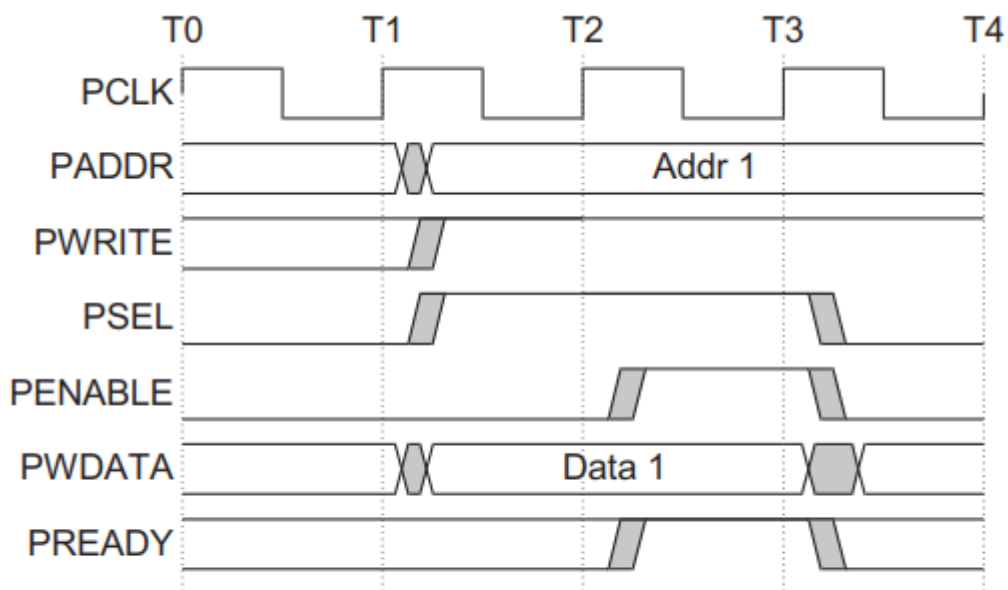

Figure 3-1 Write transfer with no wait states

2.2 apb写等

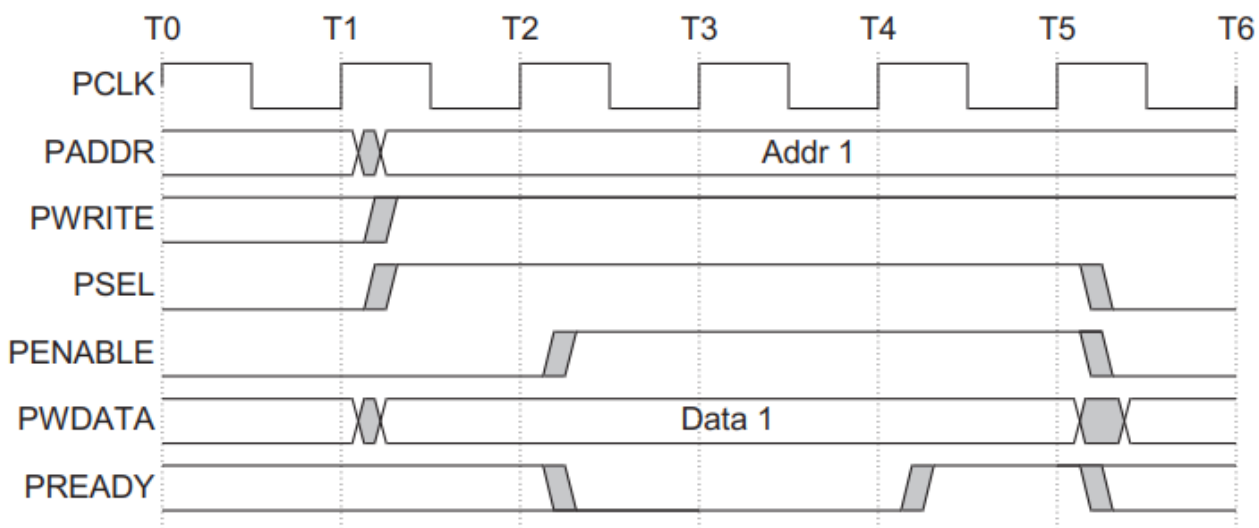

Figure 3-2 Write transfer with wait states

2.3 apb读不等

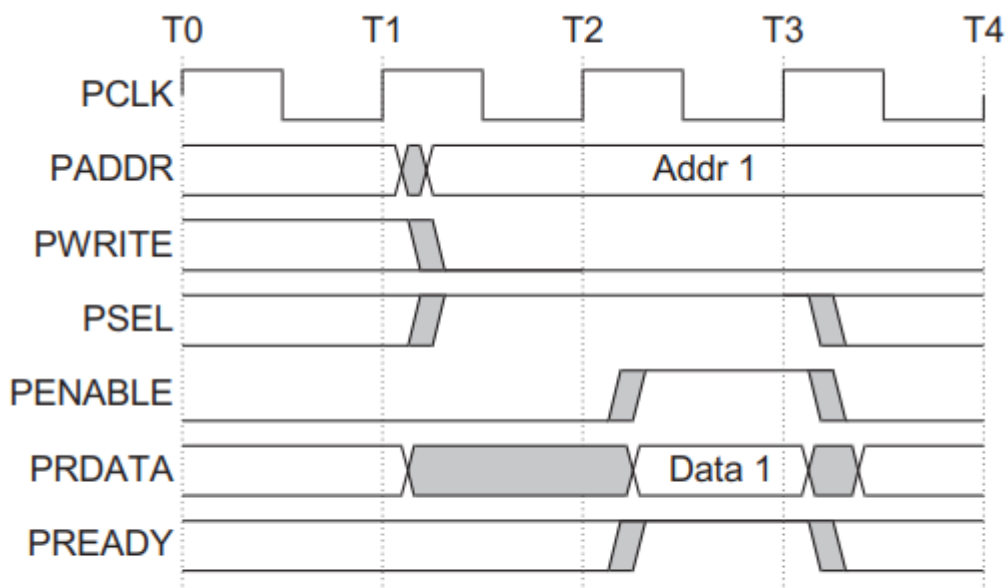

Figure 3-4 Read transfer with no wait states

2.4 apb读等

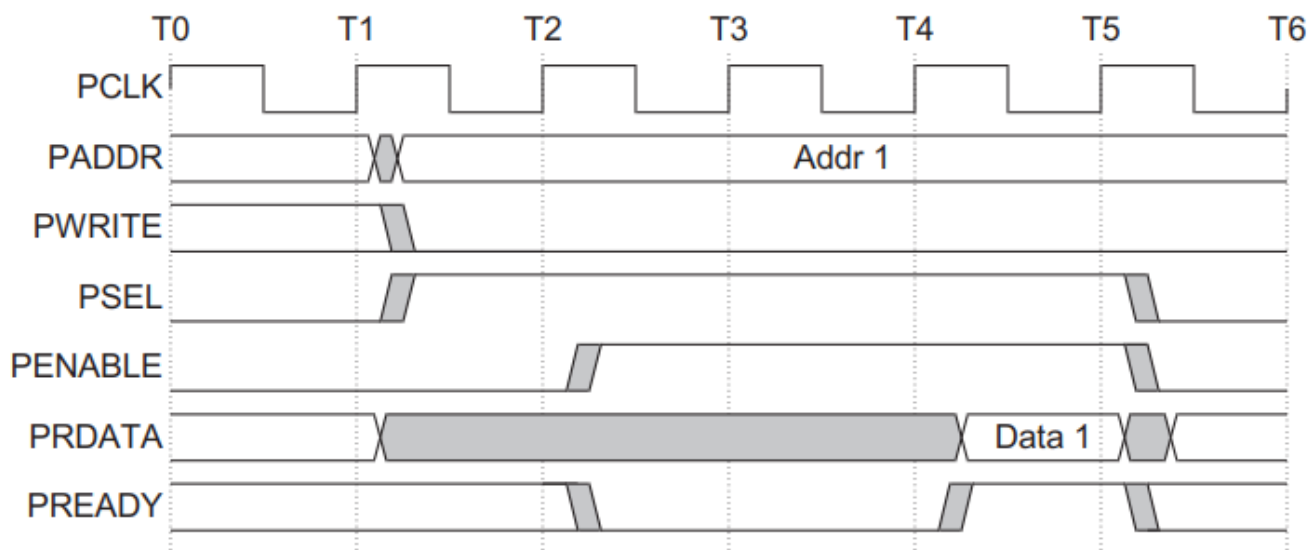

Figure 3-5 Read transfer with wait states